

Harmonic Planetary®

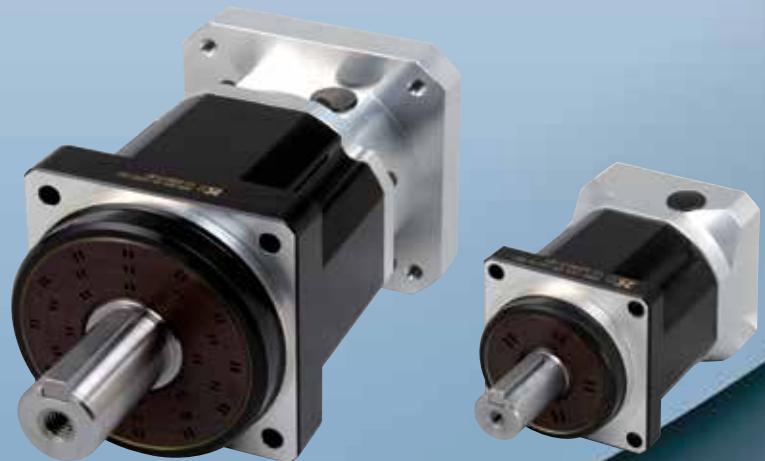

High-Performance Gearheads for Servo and Stepper Motors

HPN Series



Revolutionary Technology for Evolving Industries

Harmonic Drive LLC engineers and manufactures precision servo actuators, gearheads and gear component sets. We work with industry-leading customers and companies of all sizes to provide both standard product and custom-engineered solutions to meet their mission critical application requirements. The majority of the products sold by HDLLC are proudly made at our US headquarters and manufacturing facility in Massachusetts. Affiliated companies in Japan (Harmonic Drive Systems, Inc.) and Germany (Harmonic Drive AG) provide additional manufacturing capabilities.

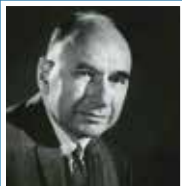

1955

Walt Musser's Patent Application for Strain Wave Gearing

1963

Harmonic Drive® components used in inertial damping system for an unmanned helicopter

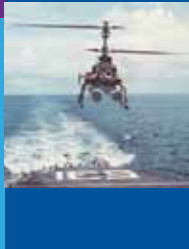

Photo credit: NASA

1971

Lunar Rover was first driven on the moon by Dave Scott. Each of the Rover's wheels were driven by a Hermetically Sealed Harmonic Drive® actuator

1977

Developed first mechatronic products (Servo Actuators) combining Harmonic Drive® gearing with servo motors and feedback sensors



1986

First use of Harmonic Drive® gear used in semiconductor wafer handling robot

1988

"S" Tooth Profile was patented providing double the torque, double the life and double the stiffness









1990

Began production of planetary gears

With over 50 years of experience, our expert engineering and production teams continually develop enabling technologies for the evolving motion control market. We are proud of our outstanding engineering capabilities and successful history of providing customer specific solutions to meet their application requirements.

Our high-precision, zero-backlash Harmonic Drive® gears and Harmonic Planetary® gears play critical roles in robotics, spaceflight applications, semiconductor manufacturing equipment, factory automation equipment, medical diagnostics and surgical robotics.

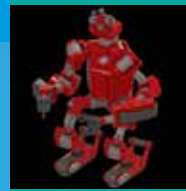
						
<p>1998</p> <p>Market introduction of high-precision HPG Harmonic Planetary® gearheads with low backlash for life</p>	<p>1999</p> <p>Ultra-flat Harmonic Drive® gearing developed</p>	<p>2004</p> <p>Mars Exploration Rover Opportunity began a 90-day mission to explore the surface of Mars. 10* years later it is still operating and making new discoveries</p>	<p>2004</p> <p>Market introduction of the CSG high torque Harmonic Drive® gear with increased torque capacity and life</p>	<p>2011</p> <p>Robonaut 2 launches on STS-133 and becomes the first permanent robotic crew member of the International Space Station</p>	<p>2011</p> <p>Introduction of Hollow Shaft Harmonic Planetary® gear unit</p>	<p>2015</p> <p>2015 DARPA Robotics Challenge</p>

Innovative, High-Performance Gearheads for Servomotors

High Accuracy, High Torsional Stiffness, Long Life

Precision Harmonic Planetary® gearheads offer high performance for servomotors with a wide range of available gear ratios and torque capacities.

Building a high precision actuator can be easily achieved by coupling a servomotor to one of our HPN Quick Connect® gearheads.

You can create a high precision actuator by connecting any manufacturer's servomotor to our precision gearhead with our Quick Connect® coupling.

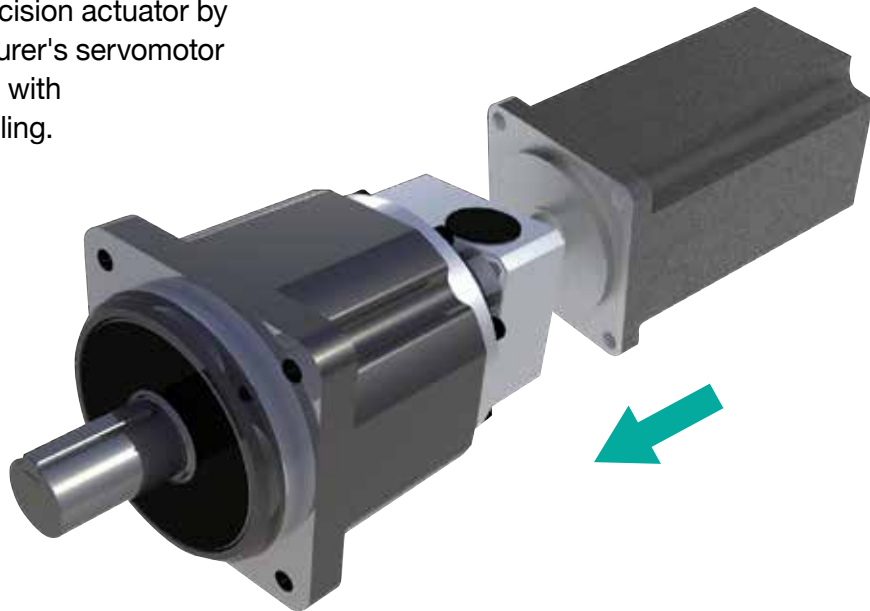

HarmonicPlanetary®
HPN Standard Series
(Peak torque 9Nm to 752Nm)



Size	Outline Dimension (mm)	Reduction ratio *1	Backlash		Motor power
			One stage	Two stage	
11	□42	4, 5, 7, 10, 15, 20, 25, 30, 35, 40, 45, 50	≤ 5 arc-min	≤ 7 arc-min	30W ~ 150W
14	□60				100W ~ 600W
20	□90	200W ~ 2kW			
32	□115	400W ~ 7kW			
40	□142	500W ~ 7.5kW			

*1 One stage reduction ratio - 3, 4, 5, 7, 10, two stage reduction ratio - 15, 20, 25, 30, 35, 40, 45, 50.

HarmonicPlanetary® HPN Value Series

Size

11, 14, 20, 32, 40

5
Sizes

Peak Torque

9Nm ~ 752Nm

Reduction Ratio

Single stage: 3:1 to 10:1, Two stage: 15:1 to 50:1

Backlash

Single stage: < 5 arc-min, Two stage: < 7 arc-min

High Efficiency

Up to 97%

Output Bearing System

Output shaft supported by dual radial ball bearing system. The two bearings straddle the planet carrier maximizing tilting moment capacity.

Easy mounting to a wide variety of servomotors

Quick Connect® motor adaptation system includes a clamshell style servo coupling and piloted adapter flange.

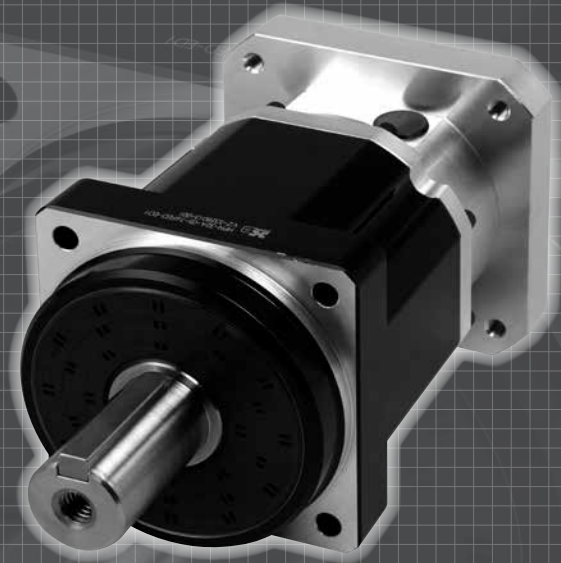

CONTENTS

Rating, Performance Table	9-10
Outline Dimensions	11-15
Product Sizing & Selection	16-17
Efficiency	20
Output Shaft Bearing Load Limits	24
Assembly	25
Lubrication	27
Safety	29

HPN Series HarmonicPlanetary®
High-Performance Gearhead for Servomotors

HPN - 14 - A - 05 - Z - J6 - Motor Code

Model Name	Size	Design Revision	Reduction Ratio	Input Side Bearing	Output Configuration	Input Configuration
HarmonicPlanetary® HPN High Torque	11	A	4, 5, 7, 10, 15, 20, 25, 30, 35, 40, 45, 50	Z: Input side bearing with double non-contact shields D: Input side bearing with double contact seals. (Recommended for output shaft up orientation.)	J6: Shaft output with key and center tapped hole J8: Shaft output with center tapped hole	This code represents the motor mounting configuration. Please contact us for a unique part number based on the motor you are using.
	14					
	20					
	32					
	40					

Gearhead Construction

Figure 05-1

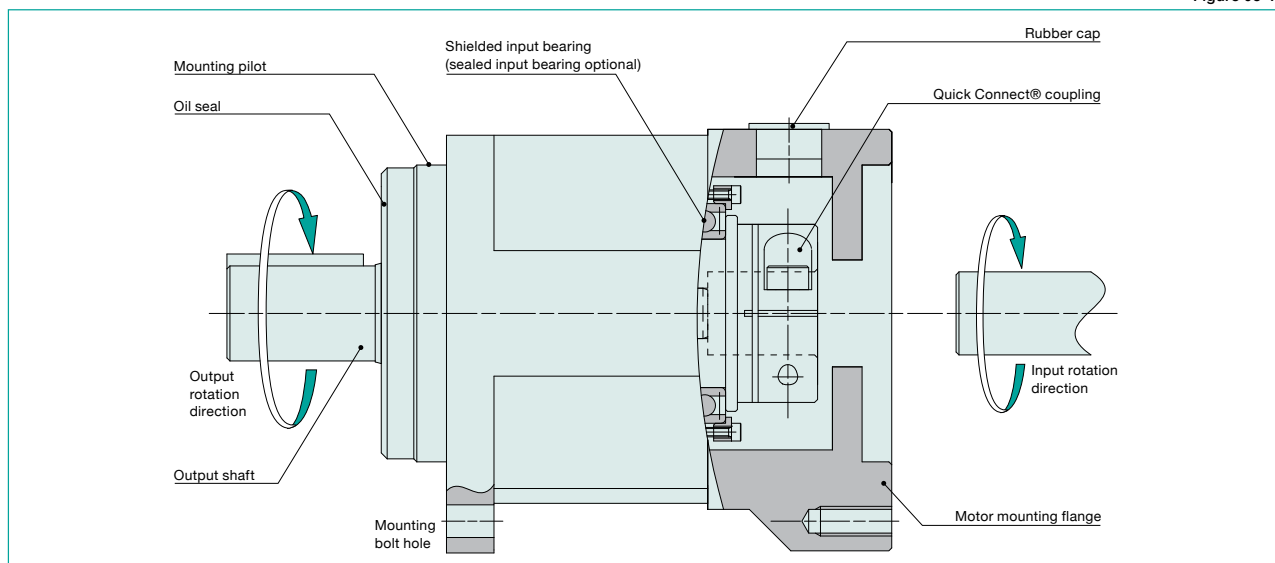

HarmonicPlanetary[®] HPN Value Series

HPN Precision Planetary Gearheads are Quiet, Lightweight and Compact with Low Cost and Quick Delivery.

HPN Planetary gearheads feature a robust design utilizing helical gears for quiet performance and long life. These gearheads are available with short lead times and are designed to couple to any servomotor with our Quick Connect[®] coupling. HPN gearheads are suitable for use in a wide range of applications for precision motion control and positioning. HPN Harmonic Planetary[®] gears are available in 5 sizes: 11, 14, 20, 32, and 40, with reduction ratios ranging from 3:1 to 50:1.

- ◆ **Backlash: Single Stage <5 arc-min, Two Stage <7 arc-min**
- ◆ **Gear Ratios: Single Stage: 3:1 to 10:1, Two Stage: 15:1 to 50:1**
- ◆ **High Efficiency**
- ◆ **Helical Gearing**
- ◆ **Quiet Design: Noise <56dB**



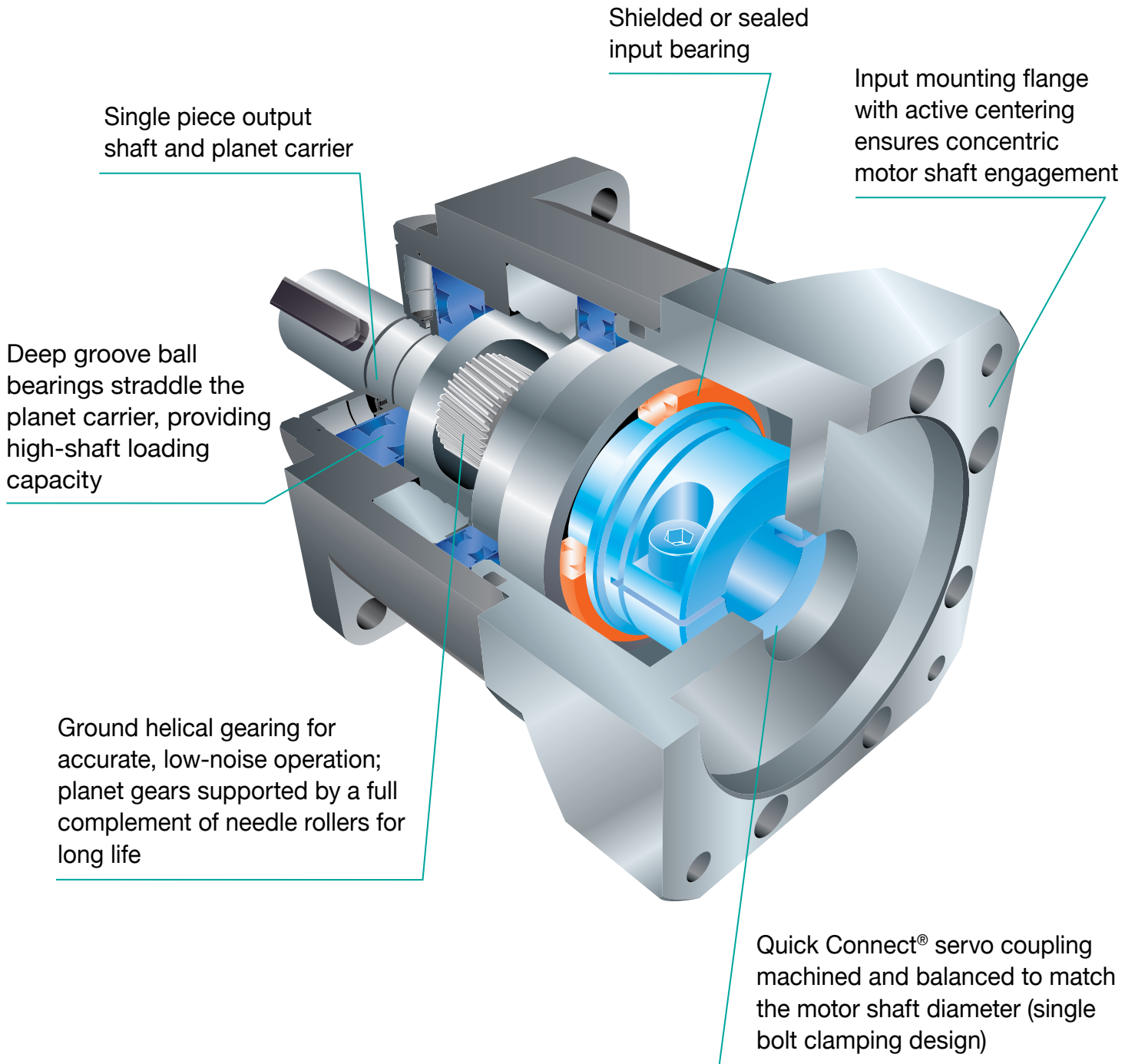

Application Examples for Harmonic Planetary® Gearheads

The Harmonic Planetary® gearheads are especially suitable for a wide range of high technology fields requiring precision motion control.

Linear axis for robots (Racks and pinion)

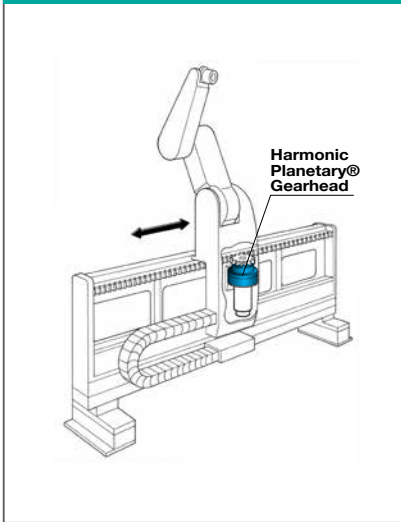

Gantry robots

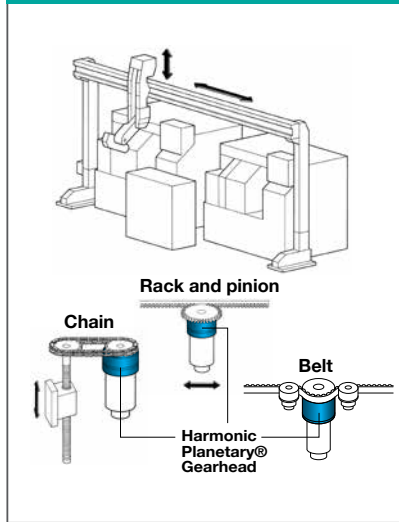

Linear axis drive

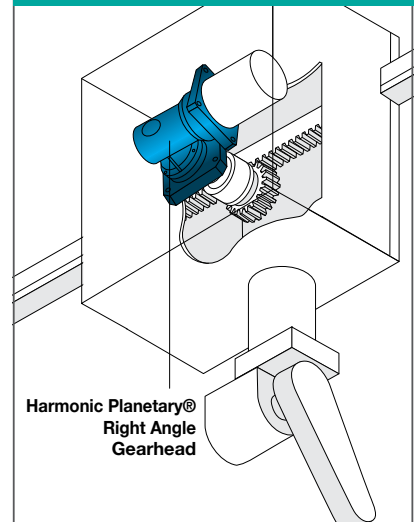

Wafer transfer robots

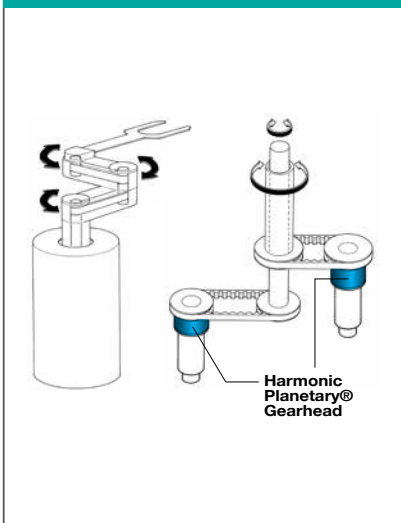

Electric presses

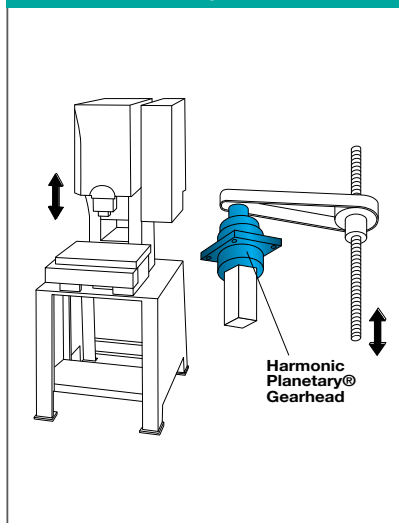

Pipe benders

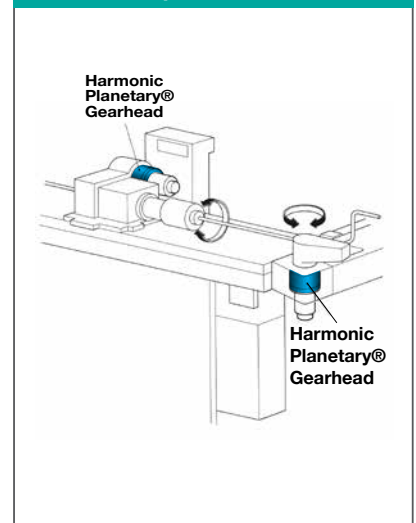

Injection molding unloading robots

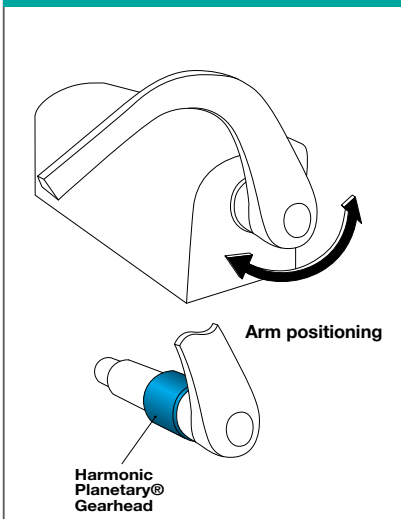

Tensile strength testers

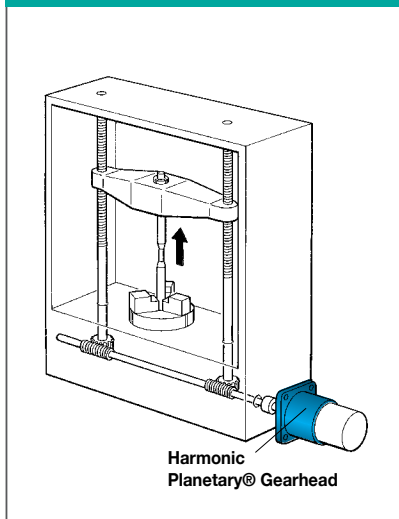

X-Y axes of machine tools

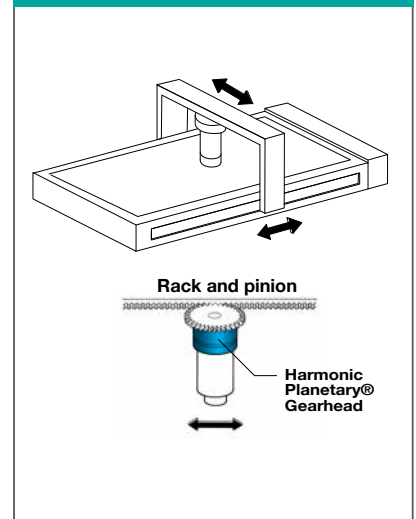

HPN Series Harmonic Planetary® High-Performance Gearhead for Servomotors

Rating Table

Table 09-1

Size	Number of Stages	Ratio	Rated Torque L10 *1	Rated Torque L50 *1	Limit for Repeated Peak Torque *2	Limit for Momentary Torque *3	Max. Average Input Speed*4	Max. Input Speed*6	Allowable Radial Load*6	Allowable Axial Load*7						
			Nm	Nm	Nm	Nm	rpm	rpm	N	N						
11	1	4	9	14	14	40	3,000	10,000	480	640						
		5	9	14	16	40										
		7	8	11	11	40										
		10	7	9	9	40										
	2	15	11	18	24	40										
		20	13	22	24	40										
		25	13	20	24	40										
		30	15	25	26	40										
		35	16	26	26	40										
		40	17	26	26	40										
		45	17	26	26	40										
		50	18	26	26	40										
		14	1	3	14	22					25	89	3,000	6,000	840	900
				4	18	28					50	110				
5	18			29	50	107										
7	20			30	37	100										
2	10		14	18	18	79										
	15		21	30	43	97										
	20		23	30	49	100										
	25		26	30	38	102										
	30		26	40	48	98										
	35		28	40	49	99										
	40		29	30	38	100										
	45		29	30	38	100										
	50		20	26	26	94										
	20		1	3	31	51	74	226	3,000	6,000	1,800	2,200				
4		50		80	130	256										
5		52		80	149	256										
7		55		80	113	256										
2		10	41	54	54	216										
		15	59	80	129	256										
		20	66	80	147	256										
		25	72	80	114	256										
		30	72	80	139	250										
		35	79	80	112	256										
		40	81	80	112	256										
		45	84	80	112	256										
		50	58	75	75	216										
		32	1	3	94	153	254	625					3,000	6,000	3,900	3,800
4	122			198	376	625										
5	127			200	376	625										
7	135			200	376	625										
2	10		128	185	185	625										
	15		146	200	376	625										
	20		162	200	376	625										
	25		176	200	376	625										
	30		179	250	376	625										
	35		193	250	376	625										
	40		200	300	376	625										
	45		206	300	376	625										
	50		193	251	251	625										
	40		1	3	272	440	752	1137	3,000	6,000	5,500	5,400				
4		287		460	752	1265										
5		298		480	752	1265										
7		317		510	752	829										
2		10	302	480	509	829										
		15	342	530	752	1265										
		20	380	600	752	1265										
		25	413	650	752	1127										
		30	421	650	752	1265										
		35	452	700	752	1127										
		40	468	700	752	1127										
		45	484	700	752	1127										
		50	432	562	562	1162										

*1: Rated torque is based on life of 20,000 hours at max average input speed.

*2: The limit for torque during start and stop cycles.

*3: The limit for torque during emergency stops or from external shock loads. Always operate below this value.

*4: Max value of average input rotational speed during operation.

*5: Maximum instantaneous input speed.

*6: The load at which the output bearing will have 20,000 hour life at 100 rpm output speed (Axial load = 0 and radial load point is in the center of the output shaft)

*7: The load at which the output bearing will have 20,000 hour life at 100 rpm output speed (Radial load = 0 and axial load point is in the center of the output shaft)

Performance

Table 010-1

Size	Number of Stages	Ratio	Backlash	Noise*1	Torsional Stiffness	
			arc min	dB	kgfm/arc-min	X100N·m/rad
11	1	4	< 5	< 56	0.060	20
		5				
		7				
		10				
	2	15	< 7			
		20				
		25				
		30				
		35				
		40				
14	1	3	< 5	< 58	0.27	93
		4				
		5				
		7				
	2	10	< 7			
		15				
		20				
		25				
		30				
		35				
20	1	40	< 5	< 60	0.77	260
		45				
		50				
		3				
	2	4	< 7			
		5				
		7				
		10				
		15				
		20				
25						
30						
35						
40						
45						
50						

Table 010-2

Size	Number of Stages	Ratio	Backlash	Noise*1	Torsional Stiffness	
			arc min	dB	kgfm/arc-min	X100N·m/rad
32	1	3	< 5	< 63	2.8	940
		4				
		5				
		7				
	2	10	< 7			
		15				
		20				
		25				
		30				
		35				
40	1	40	< 5	< 65	4.2	1430
		45				
		50				
		3				
	2	4	< 7			
		5				
		7				
		10				
		15				
		20				
25						
30						
35						
40						
45						
50						

*1: The above noise values are reference values.

HPN Series HarmonicPlanetary®
 High-Performance Gearhead for Servomotors

HPN-11A Outline Dimensions

Figure 011-1
(Unit: mm)

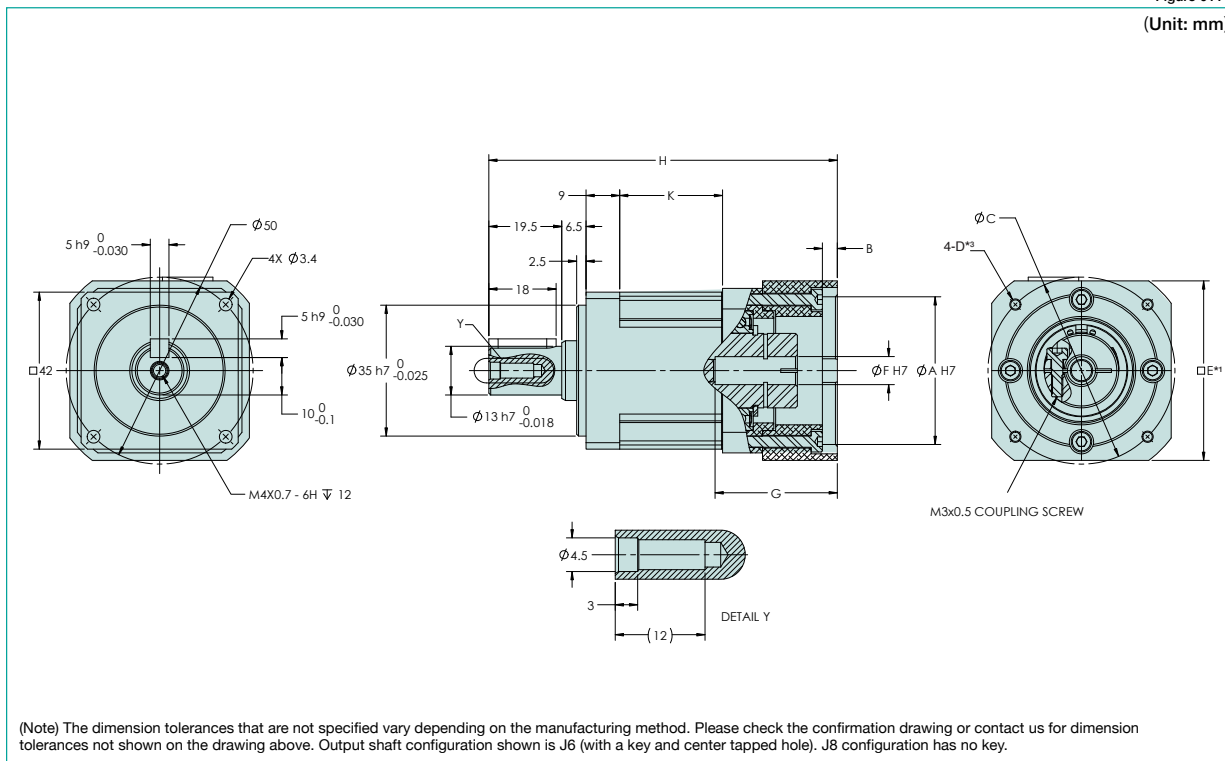

Dimension Table

(Unit: mm) Table 011-1

	A (H7) ^{*1}		B ^{*1}	C ^{*1}		F (H7) ^{*1}		G ^{*1}		H ^{*1}	K	Mass(kg) ^{*2}
	Min.	Max.	Max.	Min.	Max.	Min.	Max.	Min.	Max.			
Single Stage	20	55	3	30	75	5	9	18	29	93.5	27.5	0.44
Two Stage										113	47	0.57

Refer to the confirmation drawing for detailed dimensions. Dimensions of typical products are shown. Please contact us for other mounting options if the configurations shown above are not suitable for your particular motor.

*1 May vary depending on motor interface dimensions.

*2 The mass will vary slightly depending on the ratio and on the inside diameter of the input shaft coupling.

*3 Tapped hole for motor mounting screw.

Moment of Inertia

(10⁻⁴ kgm²) Table 011-2

HPN-11A	Ratio Coupling	4	5	7	10	15	20	25	30	35	40	45	50
		1	0.042	0.040	0.038	0.037	0.042	0.040	0.040	0.038	0.038	0.038	0.037

HPN-14A Outline Dimensions

Figure 012-1
(Unit: mm)

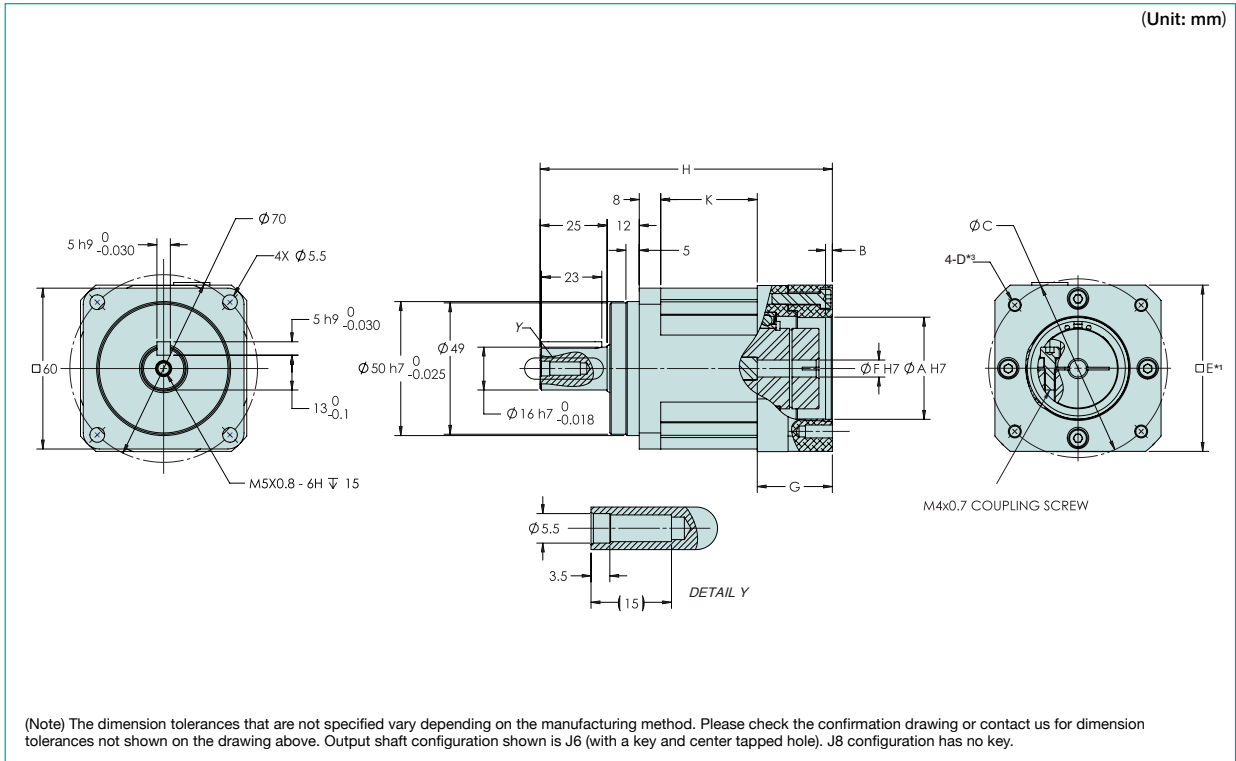

(Note) The dimension tolerances that are not specified vary depending on the manufacturing method. Please check the confirmation drawing or contact us for dimension tolerances not shown on the drawing above. Output shaft configuration shown is J6 (with a key and center tapped hole). J8 configuration has no key.

Dimension Table

(Unit: mm) Table 012-1

	Flange	Coupling	A (H7) ^{*1}		B ^{*1}	C ^{*1}		F (H7) ^{*1}		G ^{*1}		H ^{*1}	K	Mass(kg) ^{*2}
			Min.	Max.	Max.	Min.	Max.	Min.	Max.	Min.	Max.			
Single Stage	3	3	35	75	5	40	100	6	14	18	28	117	36	0.95
Two Stage												142	61	1.3

Refer to the confirmation drawing for detailed dimensions. Dimensions of typical products are shown. Please contact us for other mounting options if the configurations shown above are not suitable for your particular motor.

^{*1} May vary depending on motor interface dimensions.

^{*2} The mass will vary slightly depending on the ratio and on the inside diameter of the input shaft coupling.

^{*3} Tapped hole for motor mounting screw.

Moment of Inertia

(10⁻⁴ kgm²) Table 012-2

HPN-14A	Ratio	3	4	5	7	10	15	20	25	30	35	40	45	50
	Coupling	0.26	0.23	0.21	0.20	0.20	0.20	0.20	0.20	0.19	0.19	0.19	0.19	0.19

HPN-20A Outline Dimensions

Figure 013-1

(Unit: mm)

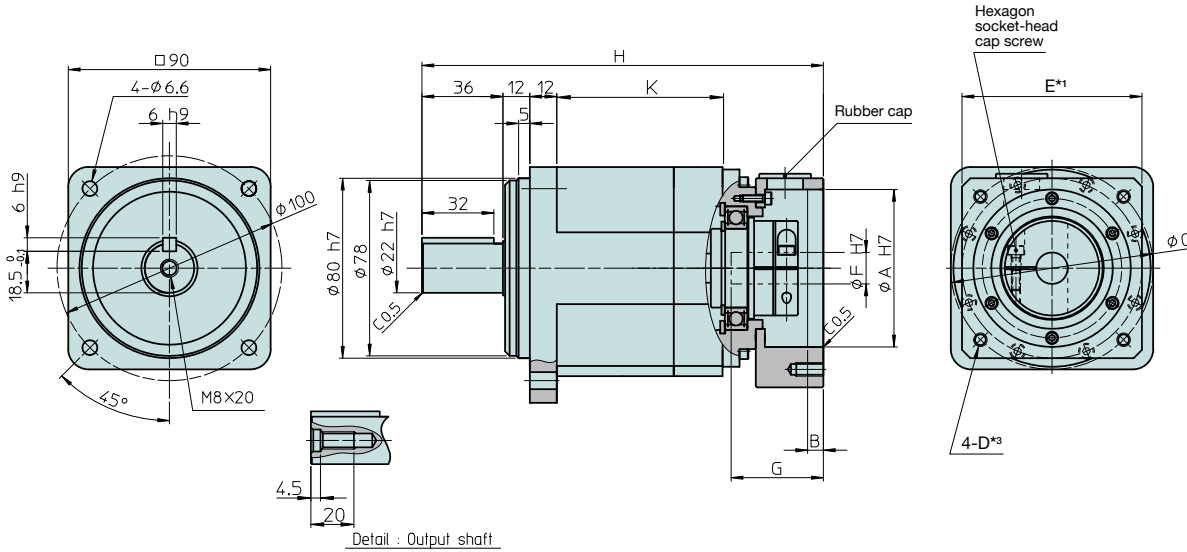

(Note) The dimension tolerances that are not specified vary depending on the manufacturing method. Please check the confirmation drawing or contact us for dimension tolerances not shown on the drawing above. Output shaft configuration shown is J6 (with a key and center tapped hole). J8 configuration has no key.

Dimension Table

(Unit: mm) Table 013-1

	Flange	Coupling	A (H7) ^{*1}		B ^{*1}	C ^{*1}		F (H7) ^{*1}		G ^{*1}		H ^{*1}	K	Mass(kg) ^{*2}
			Min.	Max.	Max.	Min.	Max.	Min.	Max.	Min.	Max.			
Single Stage	1	1	50	85	7	55	115	13.5	25.4	26	47	166.5	52	3
Two Stage										24.5	41			
Single Stage	2	1	50	125	7	60	155	13.5	25.4	44	65	184.5	52	3.7
Two Stage										42.5	59			
Single Stage	3	2	35	75	7	40	100	9.5	14.2	25.5	40.5	160	52	2.6
Two Stage										4	3			

Refer to the confirmation drawing for detailed dimensions. Dimensions of typical products are shown. Please contact us for other mounting options if the configurations shown above are not suitable for your particular motor.

*1 May vary depending on motor interface dimensions.

*2 The mass will vary slightly depending on the ratio and on the inside diameter of the input shaft coupling.

*3 Tapped hole for motor mounting screw.

Moment of Inertia

(10⁻⁴ kgm²) Table 013-2

HPN-20A	Ratio	3	4	5	7	10	15	20	25	30	35	40	45	50
	Coupling	1.20	1.00	0.92	0.87	0.86	0.86	0.87	0.87	0.85	0.86	0.85	0.85	0.85
1	1.20	1.00	0.92	0.87	0.86	0.86	0.87	0.87	0.85	0.86	0.85	0.85	0.85	0.85
2	0.53	0.36	0.29	0.24	0.21	-	-	-	-	-	-	-	-	-
3	-	-	-	-	-	0.23	0.22	0.22	0.20	0.21	0.20	0.20	0.20	0.20

HPN-32A Outline Dimensions

Figure 014-1
(Unit: mm)

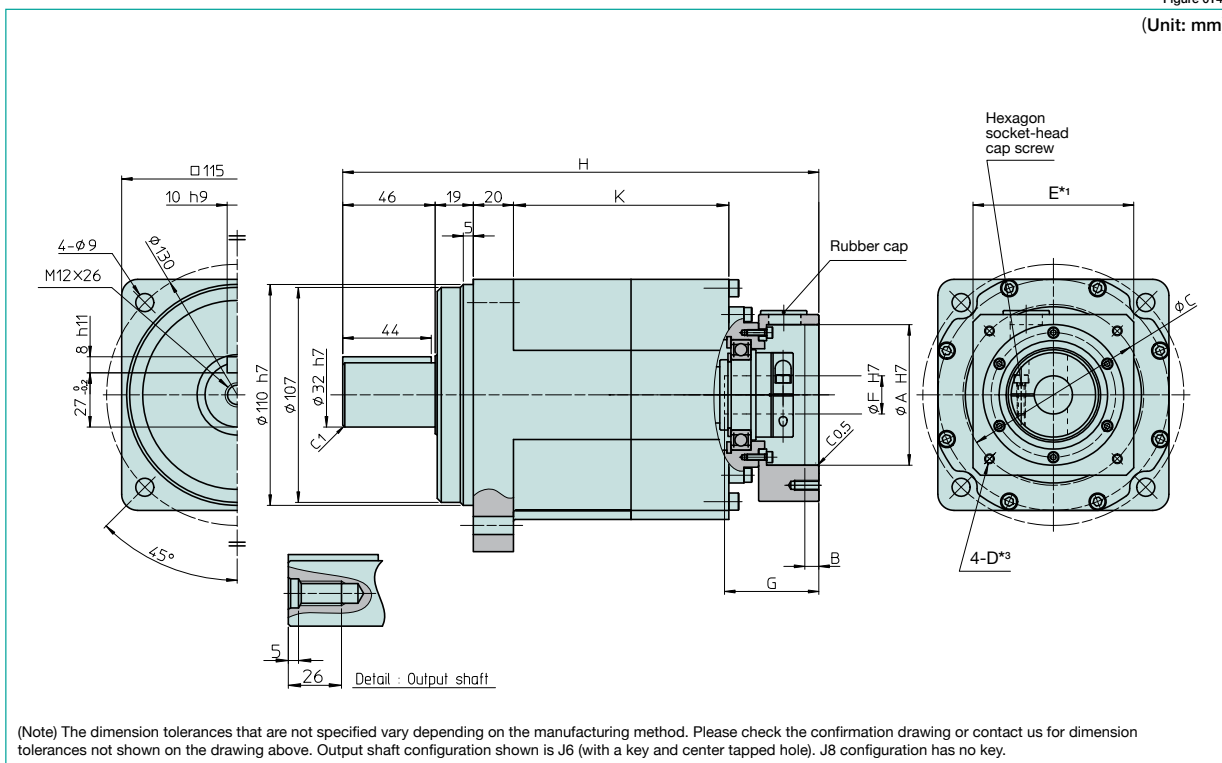

(Note) The dimension tolerances that are not specified vary depending on the manufacturing method. Please check the confirmation drawing or contact us for dimension tolerances not shown on the drawing above. Output shaft configuration shown is J6 (with a key and center tapped hole). J8 configuration has no key.

Dimension Table

(Unit: mm) Table 014-1

	Flange	Coupling	A (H7)*1		B*1	C*1		F (H7)*1		G*1		H*1	K	Mass(kg)*2
			Min.	Max.	Max.	Min.	Max.	Min.	Max.	Min.	Max.			
Single Stage	1	1	50	85	7	55	115	13.5	25.4	25	51	200	58.5	6.6
	2	2	55	125	7	65	155	15.5	28	42	64	217.5	58.5	7.7
	3	3	65	215	6.5	75	260	21.5	41	47	85	238.5	58.5	9.3
Two Stage	4	4	50	85	7	55	115	13.5	25.4	26	46.5	246.5	107.2	7.9
	5	4	50	125	7	60	155	13.5	25.4	44	65	264.5	107.2	9.1
	6	5	35	75	7	40	100	9.5	14.2	25.5	40.5	240.5	107.2	7.2

Refer to the confirmation drawing for detailed dimensions. Dimensions of typical products are shown. Please contact us for other mounting options if the configurations shown above are not suitable for your particular motor.

*1 May vary depending on motor interface dimensions.

*2 The mass will vary slightly depending on the ratio and on the inside diameter of the input shaft coupling.

*3 Tapped hole for motor mounting screw.

Moment of Inertia

(10⁻⁴ kgm²) Table 014-2

HPN-32A	Ratio	3	4	5	7	10	15	20	25	30	35	40	45	50
	Coupling													
	1	2.3	1.7	1.5	1.3	1.2	-	-	-	-	-	-	-	-
	2	4.9	3.6	3.1	2.7	2.5	-	-	-	-	-	-	-	-
	3	6.9	5.7	5.2	4.8	4.7	-	-	-	-	-	-	-	-
	4	-	-	-	-	-	1.1	1.0	1.0	0.91	0.93	0.91	0.89	0.91
	5	-	-	-	-	-	0.48	0.40	0.42	0.28	0.30	0.28	0.25	0.25

HPN-40A Outline Dimensions

Figure 015-1
(Unit: mm)

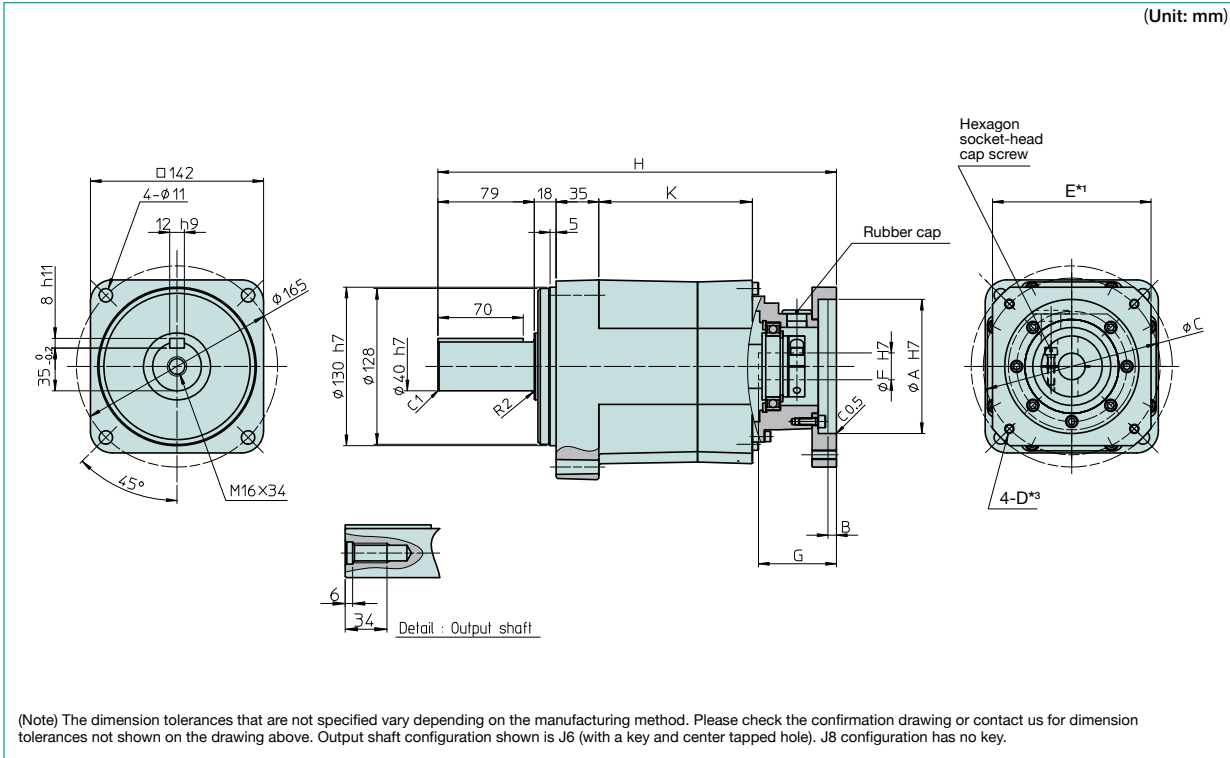

Dimension Table

(Unit: mm) Table 015-1

	Flange	Coupling	A (H7)*1		B*1	C*1		F (H7)*1		G*1		H*1	K	Mass(kg)*2
			Min.	Max.	Max.	Min.	Max.	Min.	Max.	Min.	Max.			
Single Stage	1	1	70	215	6.5	80	260	27.5	41	34.5	71.5	295.5	81	17
	2	2	70	175	6.5	80	225	42	42	39	104.5	328.5	81	16
	3	3	70	125	7	80	155	15.5	18.5	42	71.5	295.5	81	13
Two Stage	4	4	55	125	7	65	155	15.5	28.5	42	63.5	332	126	17
	5	5	65	215	6.5	75	260	21.5	41	47	84.5	353	126	18

Refer to the confirmation drawing for detailed dimensions. Dimensions of typical products are shown. Please contact us for other mounting options if the configurations shown above are not suitable for your particular motor.

*1 May vary depending on motor interface dimensions.

*2 The mass will vary slightly depending on the ratio and on the inside diameter of the input shaft coupling.

*3 Tapped hole for motor mounting screw.

Moment of Inertia

(10⁻⁴ kgm²) Table 015-2

HPN-40A	Ratio	3	4	5	7	10	15	20	25	30	35	40	45	50
	Coupling													
	1	13.6	8.8	7.0	5.9	5.1	-	-	-	-	-	-	-	-
	2	15.8	11.0	9.2	7.7	6.9	-	-	-	-	-	-	-	-
	3	12.2	7.4	5.6	4.1	3.3	-	-	-	-	-	-	-	-
	4	-	-	-	-	-	3.9	3.6	3.8	2.8	3.0	2.9	2.8	2.8
	5	-	-	-	-	-	5.9	5.6	5.9	4.9	5.3	5.1	5.0	4.9

Sizing & Selection

To fully utilize the excellent performance of the HPN HarmonicPlanetary® gearheads, check your operating conditions and, using the flowchart, select the appropriate size gear for your application.

Check your operating conditions against the following application motion profile and select a suitable size based on the flowchart shown on the right. Also, compare any application radial and axial loads supported by the gearhead output shaft to the allowable values in the ratings table to ensure an adequate output bearing service life.

Application motion profile

Review the application motion profile. Check the specifications shown in the figure below.

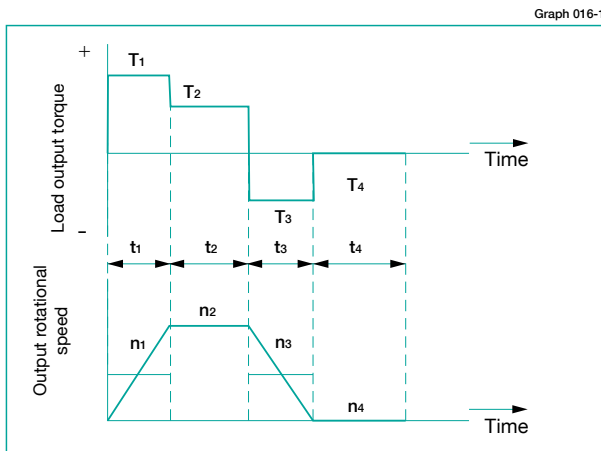

Obtain the value of each application motion profile

Load torque	T ₁ to T _n (Nm)
Time	t ₁ to t _n (sec)
Output rotational speed	n ₁ to n _n (rpm)

Normal operation pattern

Starting (Acceleration)	T ₁ , t ₁ , n ₁
Steady operation (constant velocity)	T ₂ , t ₂ , n ₂
Stopping (deceleration)	T ₃ , t ₃ , n ₃
Dwell	T ₄ , t ₄ , n ₄

Maximum rotational speed

Max. output rotational speed	n _{0 max} ≥ n ₁ to n _n
Max. input rotational speed (Restricted by motors)	n _{i max} n ₁ × R to n _n × R
	R: Reduction ratio

Emergency stop torque

When impact torque is applied	T _s
-------------------------------	----------------

Required life

$$L_{10} = L \text{ (hours)}$$

Flowchart for selecting a size

Please use the flowchart shown below for selecting a size. Operating conditions must not exceed the performance ratings.

Calculate the average load torque applied on the output side from the application motion profile: T_{av} (Nm).

$$T_{av} = \sqrt[10/3]{\frac{|n_1 \cdot t_1 \cdot |T_1|^{10/3} + |n_2 \cdot t_2 \cdot |T_2|^{10/3} + \dots + |n_n \cdot t_n \cdot |T_n|^{10/3}}{n_1 \cdot t_1 + n_2 \cdot t_2 + \dots + n_n \cdot t_n}}$$

Calculate the average output speed based on the application motion profile: no_{av} (rpm)

$$no_{av} = \frac{|n_1 \cdot t_1 + n_2 \cdot t_2 + \dots + n_n \cdot t_n}{t_1 + t_2 + \dots + t_n}$$

Make a preliminary model selection with the following condition: T_{av} ≤ Average load torque (Refer to rating table).

NG

OK

Determine the reduction ratio (R) based on the maximum output rotational speed (no_{max}) and maximum input rotational speed (n_{i max}).

$$\frac{n_{i \max}}{no_{\max}} \geq R$$

(A limit is placed on n_{i max} by motors.)

Calculate the maximum input speed (n_{i max}) from the maximum output speed (no_{max}) and the reduction ratio (R).

$$n_{i \max} = no_{\max} \cdot R$$

Calculate the average input speed (n_{i av}) from the average output speed (no_{av}) and the reduction ratio (R): n_{i av} = no_{av} · R ≤ Max. average input speed (nr).

NG

OK

Check whether the maximum input speed is equal to or less than the values in the rating table.

$$n_{i \max} \leq \text{maximum input speed (rpm)}$$

NG

OK

Check whether T₁ and T₃ are within Limit for Repeated Peak Torque (Nm) on start and stop in the rating table.

NG

OK

Check whether T_s is less than the Limit for Momentary Peak Torque (Nm) value from the ratings.

NG

OK

Calculate the life and check whether it meets the specification requirement.

T_r: Rated torque

n_r: Max. average input speed

$$L_{10} = 20,000 \cdot \left(\frac{T_r}{T_{av}} \right)^{10/3} \cdot \left(\frac{n_r}{n_{i \, av}} \right) \text{ (Hour)}$$

NG

OK

The model number is confirmed.

Refer to the Caution note below.

Review the operation conditions, size and reduction ratio.

Caution

If any of the following conditions exist, please consider selecting the next larger speed reducer, reduce the operating loads or reduce the operating speed. If this cannot be done, please contact Harmonic Drive LLC. Exercise caution especially when the duty cycle is close to continuous operation.

- i) Actual average load torque (T_{av}) > Rated Torque
- ii) Actual average input rotational speed (n_{i av}) > max. average input speed (n_r),
- iii) Gearhead housing temperature > 70°C.

Example of size selection

Load torque	T_n (Nm)	Maximum rotational speed Max. output rotational speed $no_{max} = 120$ rpm Max. input rotational speed $ni_{max} = 5,000$ rpm (Restricted by motors)
Time	t_n (sec)	
Output rotational speed	n_n (rpm)	
Normal operation pattern		Emergency stop torque When impact torque is applied $T_s = 180$ Nm
Starting (acceleration)	$T_1 = 70$ Nm, $t_1 = 0.3$ sec, $n_1 = 60$ rpm	
Steady operation (constant velocity)	$T_2 = 18$ Nm, $t_2 = 3$ sec, $n_2 = 120$ rpm	
Stopping (deceleration)	$T_3 = 35$ Nm, $t_3 = 0.4$ sec, $n_3 = 60$ rpm	
Dwell	$T_4 = 0$ Nm, $t_4 = 5$ sec, $n_4 = 0$ rpm	
		Required life $L_{50} = 30,000$ (hours)

Calculate the average load torque applied to the output side based on the load torque pattern: T_{av} (Nm).

$$T_{av} = \sqrt[10/3]{\frac{|60\text{rpm}| \cdot 0.3\text{sec} \cdot |70\text{Nm}|^{10/3} + |120\text{rpm}| \cdot 3\text{sec} \cdot |18\text{Nm}|^{10/3} + |60\text{rpm}| \cdot 0.4\text{sec} \cdot |35\text{Nm}|^{10/3}}{|60\text{rpm}| \cdot 0.3\text{sec} + |120\text{rpm}| \cdot 3\text{sec} + |60\text{rpm}| \cdot 0.4\text{sec}}}$$

Calculate the average output speed based on the load torque pattern: no_{av} (rpm)

$$no_{av} = \frac{|60\text{rpm}| \cdot 0.3\text{sec} + |120\text{rpm}| \cdot 3\text{sec} + |60\text{rpm}| \cdot 0.4\text{sec} + |0\text{rpm}| \cdot 5\text{sec}}{0.3\text{sec} + 3\text{sec} + 0.4\text{sec} + 5\text{sec}}$$

Make a preliminary model selection with the following conditions. $T_{av} = 30.2$ Nm ≤ 80 Nm. (HPN-20A-30 is tentatively selected based on the average load torque (see the rating table) of size 20 and reduction ratio of 30.)

● NG

OK

Determine a reduction ratio (R) from the maximum output speed (no_{max}) and maximum input speed (ni_{max}).

$$\frac{5,000 \text{ rpm}}{120 \text{ rpm}} = 41.7 \geq 30$$

Calculate the maximum input speed (ni_{max}) from the maximum output speed (no_{max}) and reduction ratio (R): $ni_{max} = 120 \text{ rpm} \cdot 30 = 3,720 \text{ rpm}$

Calculate the average input speed (ni_{av}) from the average output speed (no_{av}) and reduction ratio (R):
 $ni_{av} = 46.2 \text{ rpm} \cdot 30 = 1,386 \text{ rpm} \leq \text{Max average input speed of size 20 } 3,000 \text{ rpm}$

● NG

OK

Check whether the maximum input speed is less than the values specified in the rating table.
 $ni_{max} = 3,720 \text{ rpm} \leq 6,000 \text{ rpm}$ (maximum input speed of size 20)

● NG

OK

Check whether T_1 and T_3 are within limit for repeated peak torque (Nm) on start and stop in the rating table.
 $T_1 = 70 \text{ Nm} \leq 139 \text{ Nm}$ (Limit for repeated peak torque, size 20)
 $T_3 = 35 \text{ Nm} \leq 139 \text{ Nm}$ (Limit for repeated peak torque, size 20)

● NG

OK

Check whether T_s is less than limit for momentary torque (Nm) in the rating table.
 $T_s = 180 \text{ Nm} \leq 250 \text{ Nm}$ (momentary max. torque of size 20)

● NG

OK

Calculate life and check whether the calculated life meets the requirement.

$$L_{50} = 20,000 \cdot \left(\frac{80\text{Nm}}{30.2\text{Nm}}\right)^{10/3} \cdot \left(\frac{3,000\text{rpm}}{1,432\text{rpm}}\right) = 25,809,937 \text{ (hours)} \geq 30,000 \text{ (hours)}$$

● NG

OK

The selection of model number HPN-20A-30 is confirmed from the above calculations.

Refer to the Caution note at the bottom of page 16.

Review the operation conditions, size and reduction ratio.



Harmonic Planetary®

Technical Information

Efficiency	20
Output Shaft Bearing Load Limits	24

Product Handling

Assembly	25
Lubrication	27
Warranty, Disposal	28
Safety	29

Efficiency

In general, the efficiency of a speed reducer depends on the reduction ratio, input rotational speed, load torque, temperature and lubrication condition. The efficiency of each series under the following measurement conditions is plotted in the graphs on the next page. The values in the graph are average values.

Measurement condition

Table 020-1

Input rotational speed	HPN:3000rpm
Ambient temperature	25°C
Lubricant	Use standard lubricant for each model. (See page 27 for details.)

Efficiency compensated for low temperature

Calculate the efficiency at an ambient temperature of 25°C or less by multiplying the efficiency at 25°C by the low-temperature efficiency correction value. Obtain values corresponding to an ambient temperature and to an input torque (TRi*) from the following graphs when calculating the low-temperature efficiency correction value.

HPN

* TRi is an input torque corresponding to output torque at 25°C.

Graph 020-1

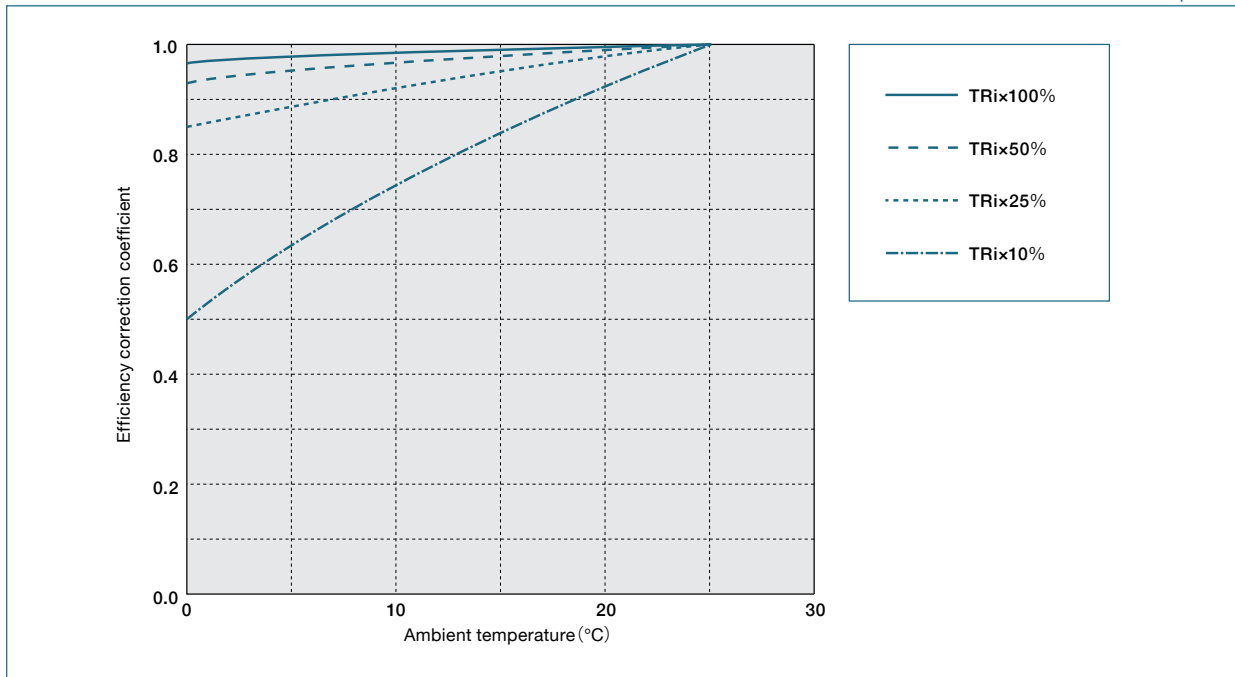

Size 11

HPN

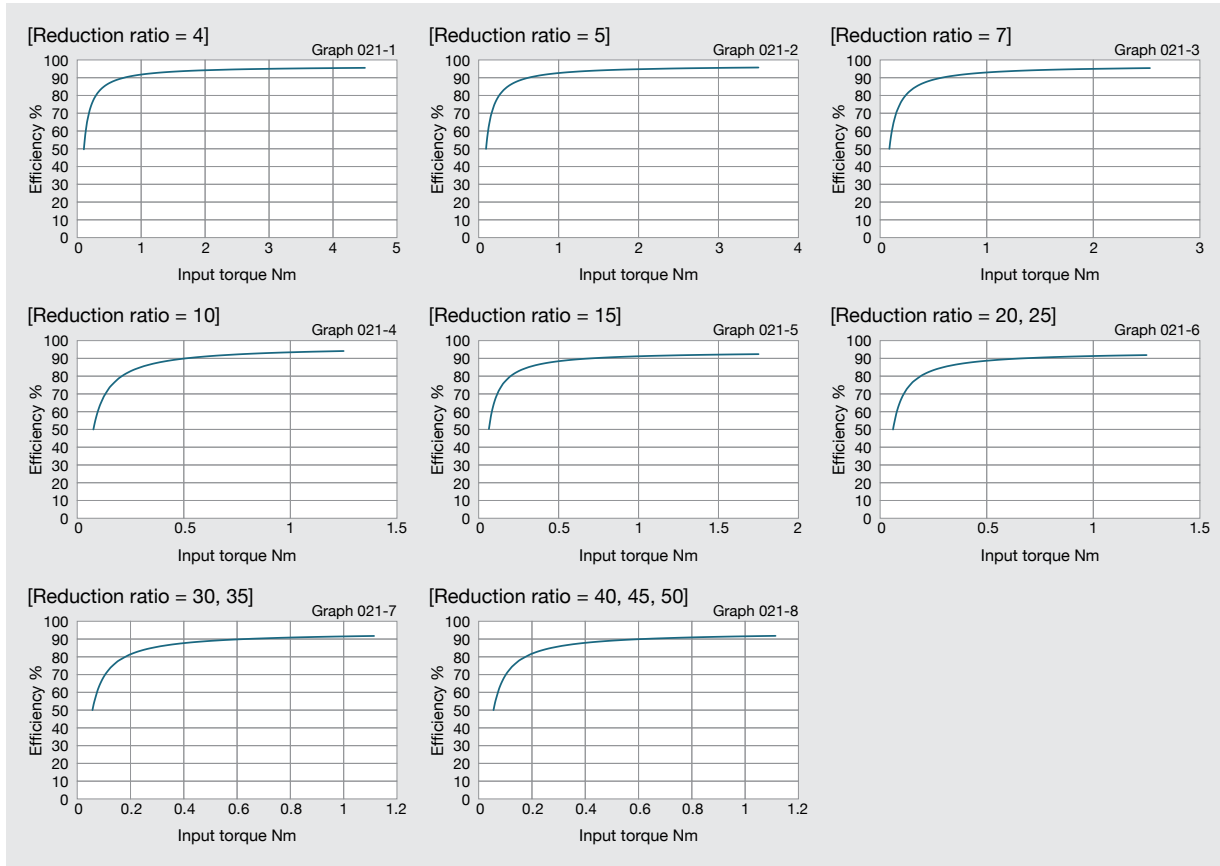

Size 14

HPN

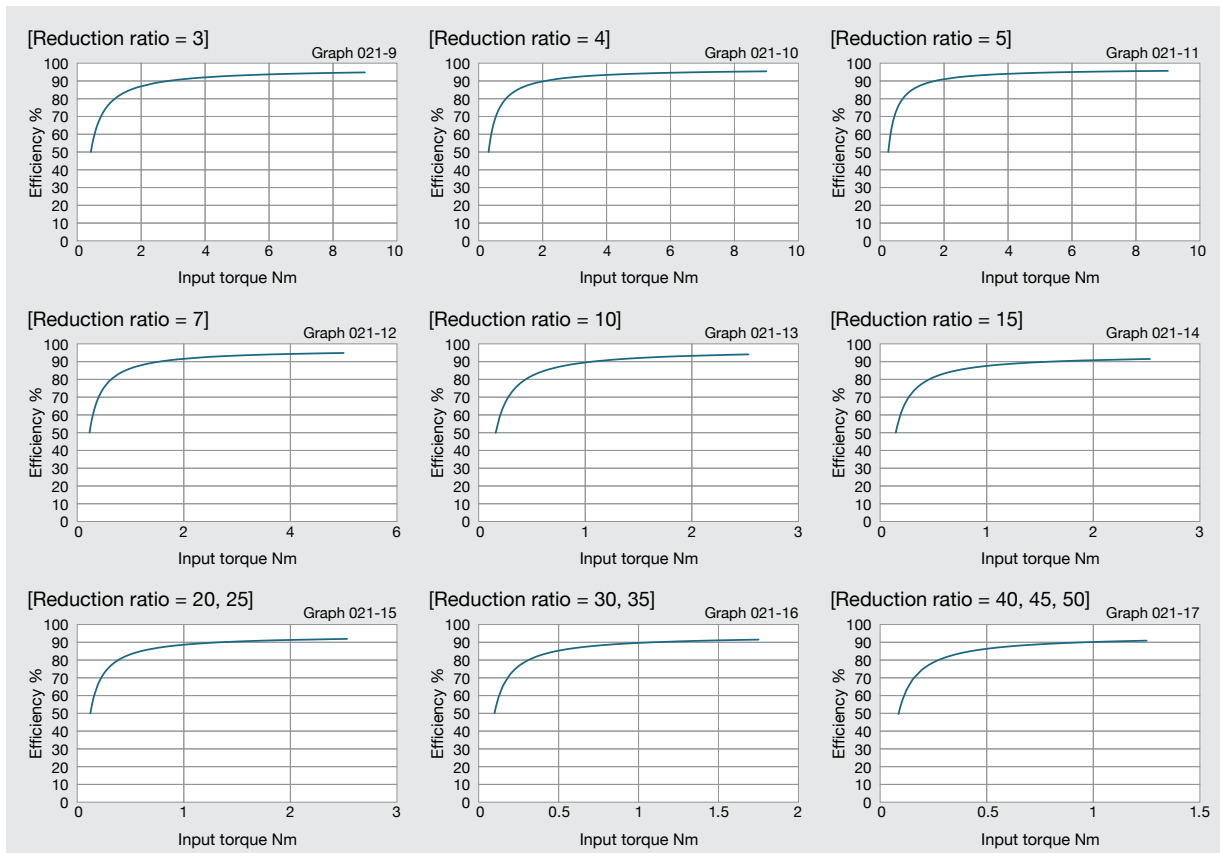

Size 20

HPN

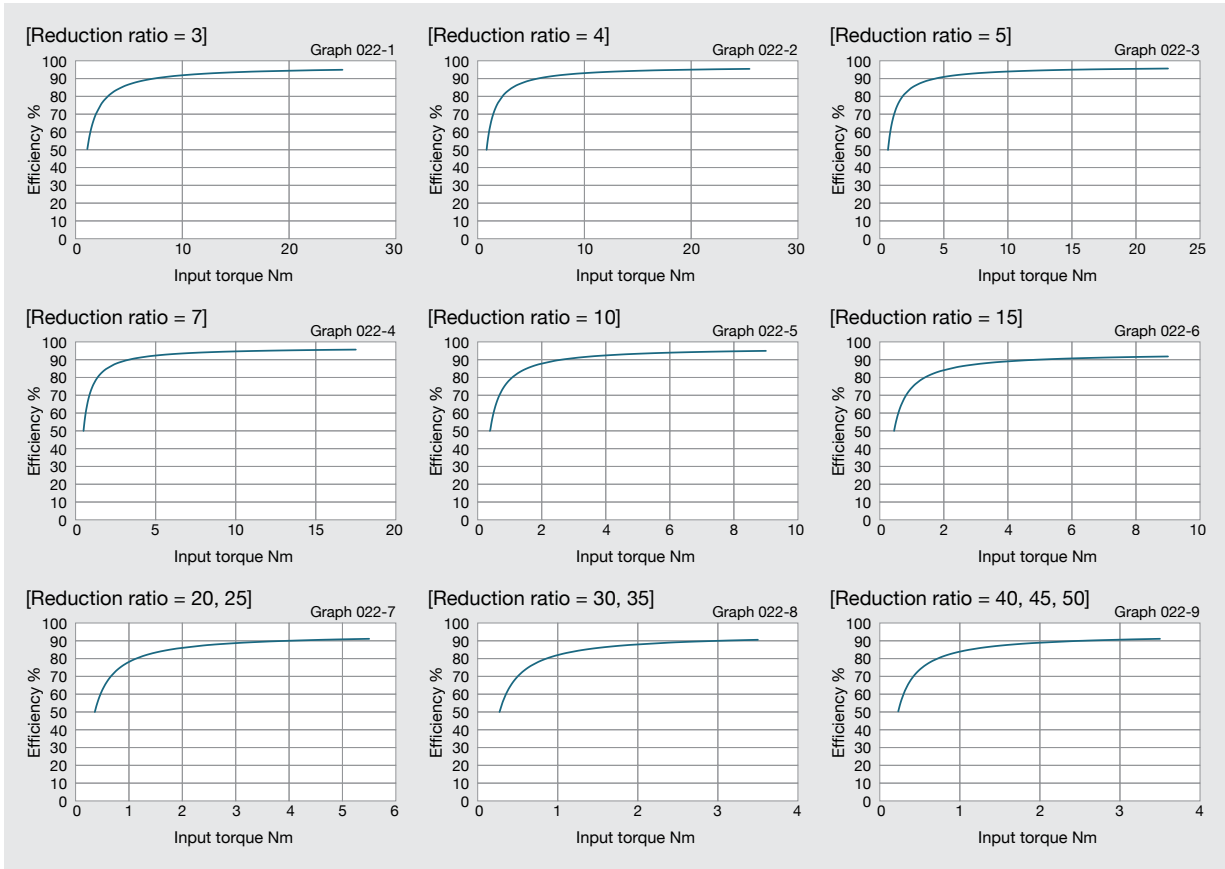

Size 32

HPN

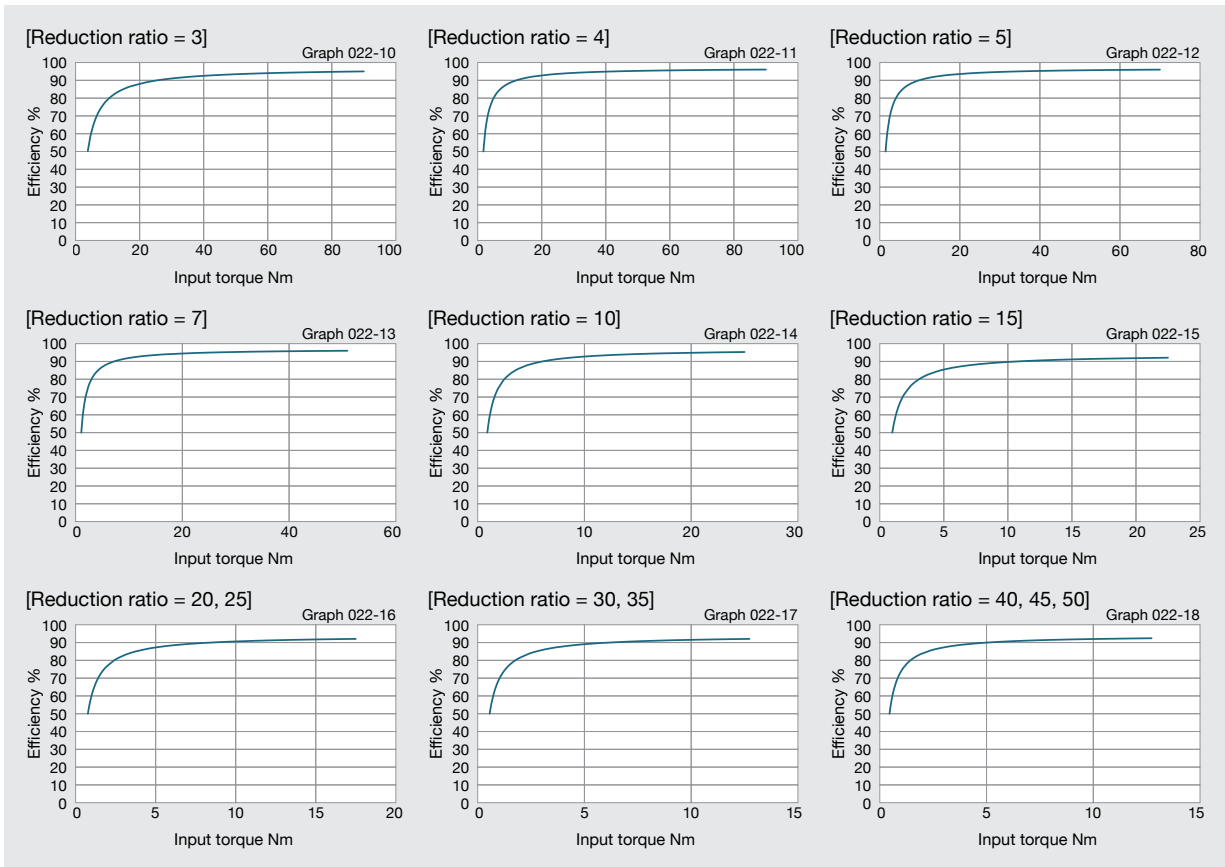

Size 40

HPN

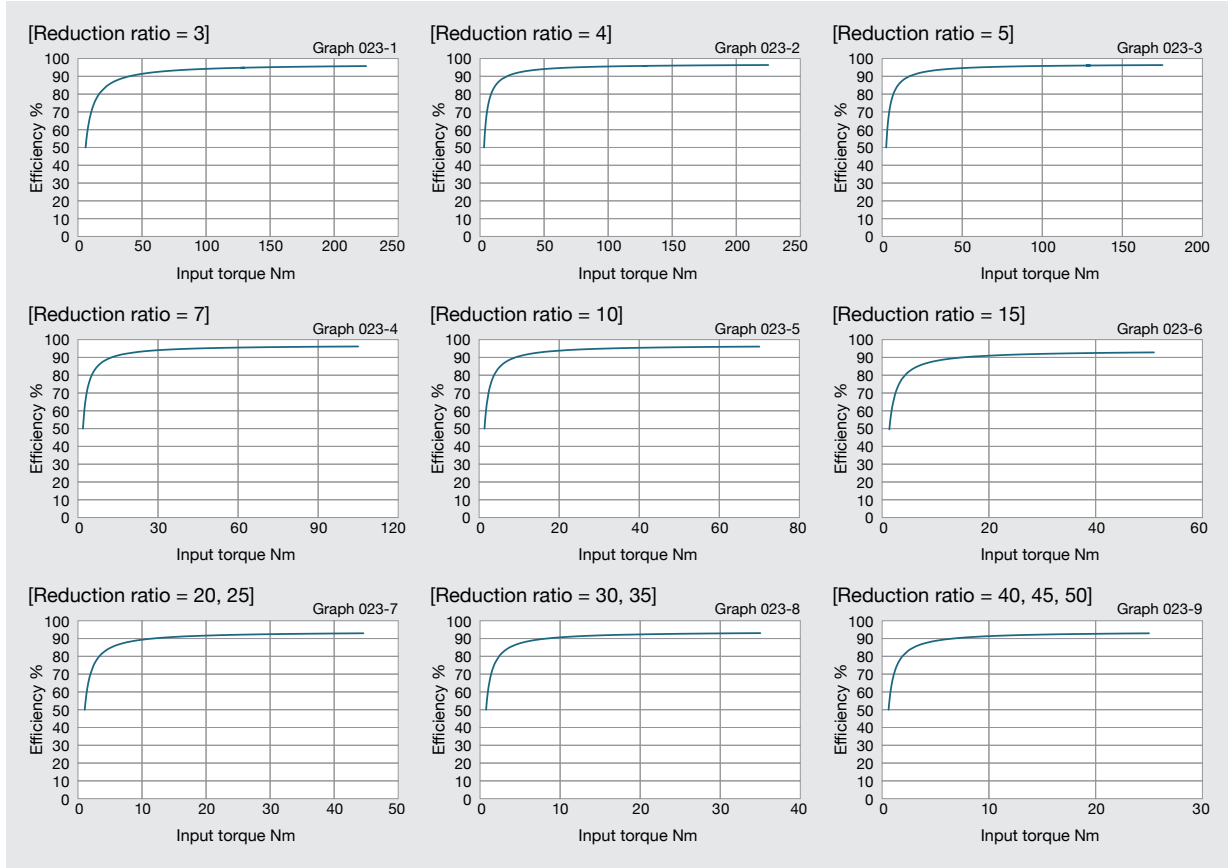

HPN Series  Technical Information / Handling / Explanation

Output Shaft Bearing Load Limits

HPN Series Output Shaft Load Limits are plotted below.

HPN uses deep groove radial ball bearings to support the output shaft. Please use the curve on the graph for the appropriate load coefficient (f_w) that represents the expected operating condition.

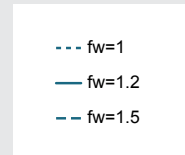
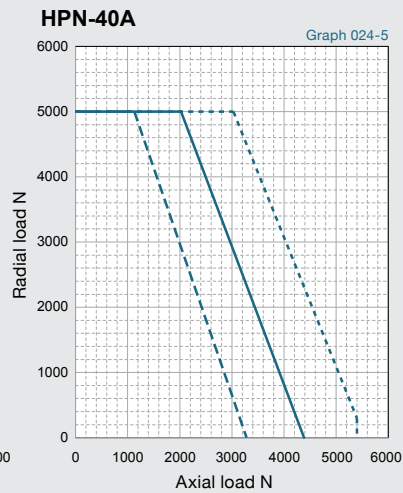
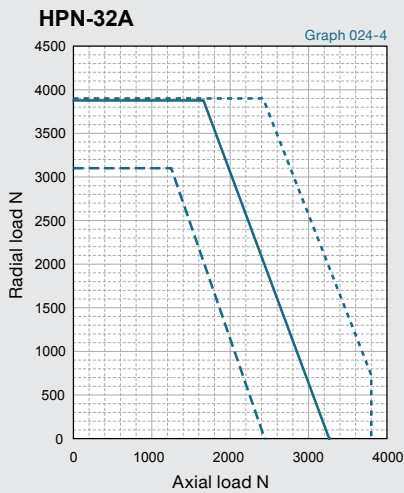
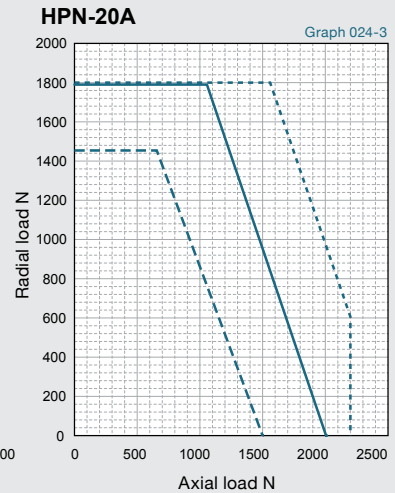
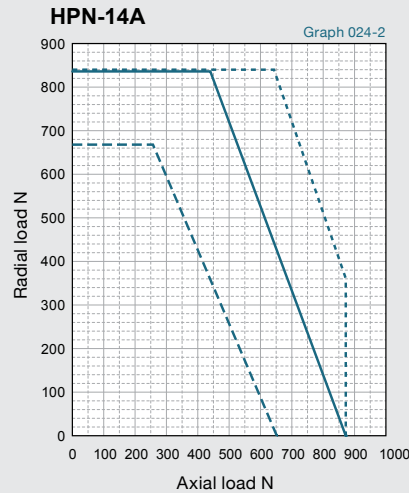
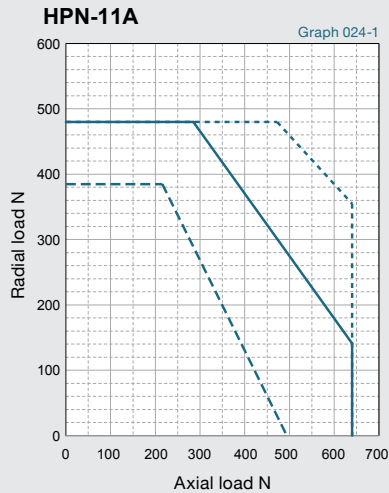

Load coefficient
 $f_w=1-1.2$ Smooth operation
 without impact
 $f_w=1.2-1.5$ Standard operation

Output shaft speed - 100 rpm, bearing life is based on 20,000 hours. The load-point is based on shaft center of radial load and axial load.

Assembly

Assemble and mount your gearhead in accordance with these instructions to achieve the best performance. Be sure to use the recommended bolts and use a torque wrench to achieve the proper tightening torques as recommended in the tables below.

Motor assembly procedure HPN

To properly mount the motor to the gearhead, follow the procedure outlined below, refer to figure 025-1

- (1) Turn the input shaft coupling and align the bolt head with the rubber cap hole.
- ↓
- (2) With the speed reducer in an upright position as illustrated in the figure below, slowly insert the motor shaft into the coupling of speed reducer. Slide the motor shaft without letting it drop down. If the speed reducer cannot be positioned upright, slowly insert the motor shaft into the coupling of speed reducer, then tighten the motor bolts evenly until the motor flange and gearhead flange are in full contact. Exercise care to avoid tilting the motor when inserting it into the gear head.

- (3) Tighten the input shaft coupling bolt to the recommended torque specified in the table below. The bolt(s) or screw(s) is (are) already inserted into the input coupling when delivered. Check the bolt size on the confirmation drawing provided.

Bolt tightening torque

Table 025-1

Bolt size		M3	M4	M5	M6	M8	M10	M12
Tightening torque	Nm	2.0	4.5	9.0	15.3	37.2	73.5	128
	kgfm	0.20	0.46	0.92	1.56	3.8	7.5	13.1

Caution: Always tighten the bolts to the tightening torque specified in the table above. If the bolt is not tightened to the torque value recommended slippage of the motor shaft in the shaft coupling may occur. The bolt size will vary depending on the size of the gear and the shaft diameter of the mounted motor. Check the bolt size on the confirmation drawing provided.

- (4) Fasten the motor to the gearhead flange with bolts.

Bolt* tightening torque

Table 025-2

Bolt size		M2.5	M3	M4	M5	M6	M8	M10	M12
Tightening torque	Nm	0.59	1.4	3.2	6.3	10.7	26.1	51.5	89.9
	kgfm	0.06	0.14	0.32	0.64	1.09	2.66	5.25	9.17

* Recommended bolt: JIS B 1176 Hexagon socket head bolt, Strength: JIS B 1051 12.9 or higher

Caution: Be sure to tighten the bolts to the tightening torques specified in the table.

- (5) Insert the rubber cap provided. This completes the assembly.

Figure 025-1

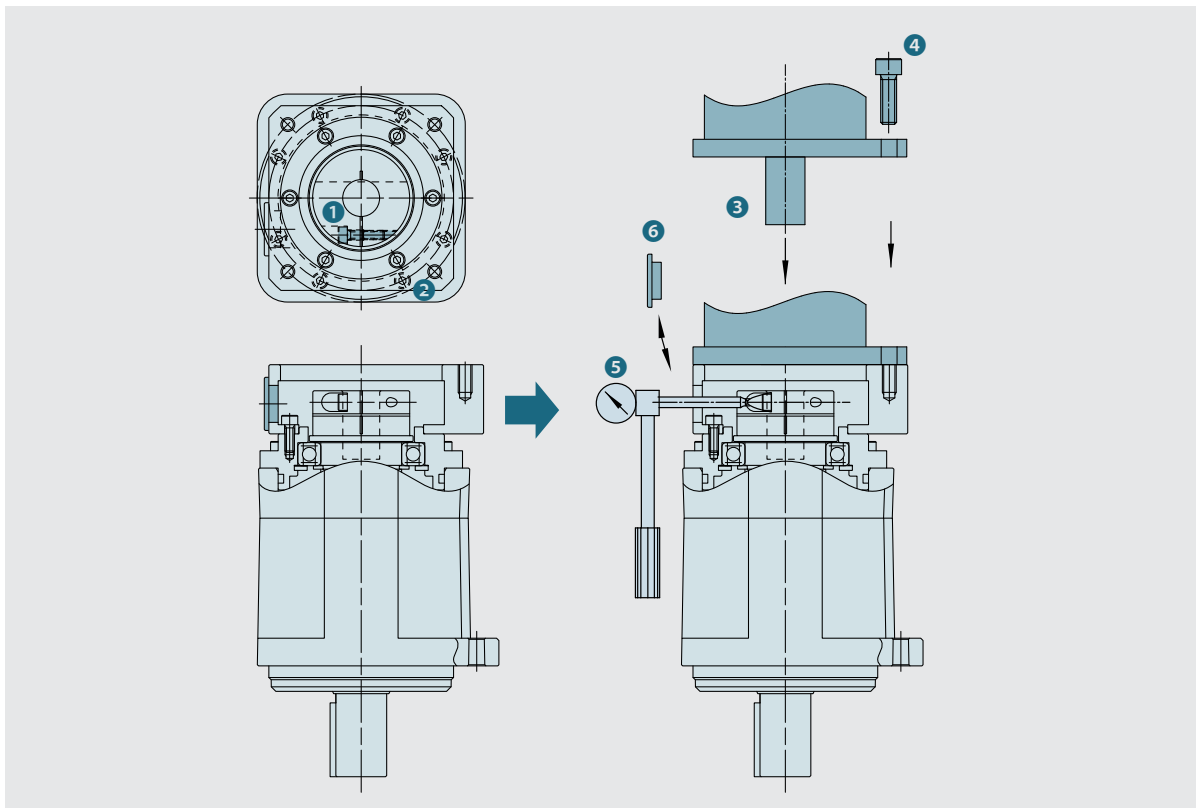

Speed reducer assembly **HPN**

When assembling gearheads into your equipment, check the flatness of your mounting surface and look for any burrs on tapped holes. Then fasten the flange (Part A in the diagram below) using appropriate bolts.

Bolt* tightening torque for flange (Part A in the diagram below) Table 026-1

Size		HPN				
		11	14	20	32	40
Number of bolts		4	4	4	4	4
Bolt size		M3	M5	M6	M8	M10
Mounting PCD	mm	50	70	100	130	165
	Nm	1.4	6.3	10.7	26.1	51.5
Tightening torque	kgfm	0.14	0.64	1.09	2.66	5.26
	Nm	27.9	110	223	528	1063
Transmission torque	kgfm	2.85	11.3	22.8	53.9	108.5

* Recommended bolts: JIS B 1176 "Hexagon socket head bolts." Strength classification 12.9 or higher in JIS B 1051.

Gearheads with an output shaft **HPN**

Do not subject the output shaft to any impact when mounting a pulley, pinion or other parts. An impact to the the output bearing may affect the speed reducer precision and may cause reduced life or failure.

Lubrication

Prevention of grease and oil leakage

- Only use the recommended greases.
- Provisions for proper sealing to prevent grease leakage are incorporated into the gearheads. However, please note that some leakage may occur depending on the application or operating condition. Discuss other sealing options with our applications engineers.
- When mounting the gearhead horizontally, position the gearhead so that the rubber cap in the adapter flange is facing upwards.

Sealing

- Provisions for proper sealing to prevent grease leakage from the input shaft are incorporated into the gearhead.
- A double lip Teflon oil seal is used for the output shaft, gaskets or o-rings are used on all mating surfaces, and non contact shielded bearings are used for the motor shaft coupling (Double sealed bearings (D type) are available as an option*).
- Material and surface: Gearbox: Aluminum, carbon steel (output shaft).
Adapter flange: (if provided by Harmonic Drive) high-strength aluminum or carbon steel. Screws: black phosphate. The ambient environment should not subject any corrosive agents to the above mentioned material. The product provides protection class IP 54 under the provision that corrosion from the ambient atmosphere (condensation, liquids or gases) at the running surface of the output shaft seal is prevented. If necessary, the adapter flange can be sealed by means of a surface seal (e.g. Loctite 515).

* D type: Bearing with a rubber contact seal on both sides

Standard Lubricants

HPN Series

The standard lubrication for the HPN series gearheads is grease. All gearheads are lubricated at the factory prior to shipment and additional application of grease during assembly is not required. The gearheads are lubricated for the life of the gear and do not require re-lubrication. High efficiency is achieved through the unique planetary gear design and grease selection.

Ambient operating temperature range: -10°C to +40°C

The lubricant may deteriorate if the ambient operating temperature is outside of recommended operating range. Please contact our sales office or distributor for operation outside of the ambient operating temperature range. The temperature rise of the gear depends upon the operating cycle, ambient temperature and heat conduction and radiation based on the customers installation of the gear. A housing surface temperature of 70°C is the maximum allowable limit.

Warranty

Please contact us or visit our website at www.harmonicdrive.net for warranty details for your specific product.

All efforts have been made to ensure that the information in this catalog is complete and accurate. However, Harmonic Drive LLC is not liable for any errors, omissions or inaccuracies in the reported data. Harmonic Drive LLC reserves the right to change the product specifications, for any reason, without prior notice. For complete details please refer to our current Terms and Conditions posted on our website.

Disposal

When disposing of the product, disassemble it and sort the component parts by material type and dispose of the parts as industrial waste in accordance with the applicable laws and regulations. The component part materials can be classified into three categories.

- (1) Rubber parts: Oil seals, seal packings, rubber caps, seals of shielded bearings on input side (D type only)
- (2) Aluminum parts: Housings, motor flanges
- (3) Steel parts: Other parts

Trademark

HarmonicDrive® is a registered trademark of Harmonic Drive LLC.

HarmonicPlanetary® is a registered trademark of Harmonic Drive LLC.

Safety

 **Warning** : Means that improper use or handling could result in a risk of death or serious injury.

 **Caution** : Means that improper use or handling could result in personal injury or damage to property.

Application Restrictions





This product cannot be used for the following applications:

- * Space flight hardware
- * Aircraft equipment
- * Nuclear power equipment
- * Equipment and apparatus used in residential dwellings
- * Vacuum environments
- * Automotive equipment
- * Personal recreation equipment
- * Equipment that directly works on human bodies
- * Equipment for transport of humans
- * Equipment for use in a special environment
- * Medical equipment

Please consult Harmonic Drive LLC beforehand if intending to use one of our product for the aforementioned applications.

Fail-safe devices that prevent an accident must be designed into the equipment when the products are used in any equipment that could result in personal injury or damage to property in the event of product failure.





Design Precaution: Be certain to read the catalog when designing the equipment.

 Caution	<p>Use only in the proper environment.</p> <ul style="list-style-type: none"> ● Please ensure to comply with the following environmental conditions: <ul style="list-style-type: none"> • Ambient temperature 0 to 40°C • No splashing of water or oil • Do not expose to corrosive or explosive gas • No dust such as metal powder 	 Caution	<p>Install the equipment properly.</p> <ul style="list-style-type: none"> ● Carry out the assembly and installation precisely as specified in the catalog. ● Observe our recommended fastening methods (including bolts used and tightening torques). ● Operating the equipment without precise assembly can cause problems such as vibration, reduction in life, deterioration of precision and product failure.
 Caution	<p>Install the equipment with the required precision.</p> <ul style="list-style-type: none"> ● Design and assemble parts to keep all catalog recommended tolerances for installation. ● Failure to hold the recommended tolerances can cause problems such as vibration, reduction in life, deterioration of precision and product failure. 	 Caution	<p>Use the specified lubricant.</p> <ul style="list-style-type: none"> ● Using other than our recommended lubricant can reduce the life of the product. Replace the lubricant as recommended. ● Gearheads are factory lubricated. Do not mix installed lubricant with other kinds of grease.

Operational Precaution: Be certain to read the catalog before operating the equipment.

 Caution	<p>Use caution when handling the product and parts.</p> <ul style="list-style-type: none"> ● Do not hit the gear or any part with a hammer. ● If you use the equipment in a damaged condition, the gearhead may not perform to catalog specifications. It can also cause problems including product failure. 	 Caution	<p>Operate within the allowable torque range.</p> <ul style="list-style-type: none"> ● Do not apply torque exceeding the momentary peak torque. Applying excess torque can cause problems such as loosened bolts, generation of backlash and product failure. ● An arm attached directly to the output shaft that strikes a solid object can damage the arm or cause the output of the gearhead to fail.
 Caution	<p>Do not alter or disassemble the product or parts.</p> <ul style="list-style-type: none"> ● Harmonic Planetary® products are manufactured as matched sets. Catalog ratings may not be achieved if the component parts are interchanged. 	 Caution	<p>Do not disassemble the products.</p> <ul style="list-style-type: none"> ● Do not disassemble and reassemble the products. Original performance may not be achieved.
 Warning	<p>Do not use your finger to turn the gear.</p> <ul style="list-style-type: none"> ● Do not insert your finger into the gear under any circumstances. The finger may get caught in the gear causing an injury. 	 Caution	<p>Stop operating the system if any abnormality occurs.</p> <ul style="list-style-type: none"> ● Shut down the system promptly if any abnormal sound or vibration is detected, the rotation has stopped, an abnormally high temperature is generated, an abnormal motor current value is observed or any other anomalies are detected. Continuing to operate the system may adversely affect the product or equipment. ● Please contact our sales office or distributor if any anomaly is detected.
 Caution	<ul style="list-style-type: none"> ● Rust-proofing was applied before shipping. However, please note that rusting may occur depending on the customers' storage environment. ● Although black oxide finish is applied to some of our products, it does not guarantee that rust will not form. 		

Handling Lubricant

 Warning	<p>Precautions on handling lubricants</p> <ul style="list-style-type: none"> ● Lubricant in the eye can cause inflammation. Wear protective glasses to prevent it from getting in your eye. ● Lubricant coming in contact with the skin can cause inflammation. Wear protective gloves when you handle the lubricant to prevent it from contacting your skin. ● Do not ingest (to avoid diarrhea and vomiting). ● Use caution when opening the container. There may be sharp edges that can cut your hand. Wear protective gloves. ● Keep lubricant out of reach of children. 	 Caution	<p>Disposal of waste oil and containers</p> <ul style="list-style-type: none"> ● Follow all applicable laws regarding waste disposal. Contact your distributor if you are unsure how to properly dispose of the material. ● Do not apply pressure to an empty container. The container may explode. ● Do not weld, heat, drill or cut the container. This may cause residual oil to ignite or cause an explosion.
 Warning	<p>First-aid</p> <ul style="list-style-type: none"> ● Inhalation: Remove exposed person to fresh air if adverse effects are observed. ● Ingestion: Seek immediate medical attention and do not induce vomiting unless directed by medical personnel. ● Eyes: Flush immediately with water for at least 15 minutes. Get immediate medical attention. ● Skin: Wash with soap and water. Get medical attention if irritation develops. 	 Caution	<p>Storage</p> <ul style="list-style-type: none"> ● Tightly seal the container after use. Store in a cool, dry, dark place. Keep away from open flames and high temperatures.
 Caution	<p>Disposal</p> <p>Please dispose of as industrial waste.</p> <ul style="list-style-type: none"> ● Please dispose of the products as industrial waste when their useful life is over. 		

Major Applications of Our Products



Metal Working Machines



Processing Machine Tools



Measurement, Analytical and Test Systems



Medical Equipment



Telescopes

Source: National observatory of Inter-University Research Institute Corporation

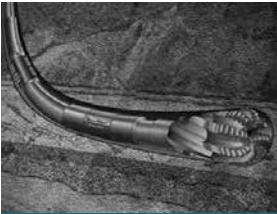

Energy

Courtesy of Halliburton/Sperry Drilling Services

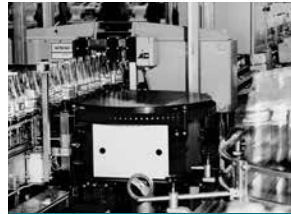

Crating and Packaging Machines



Communication Equipment



Space Flight Hardware

Rover image created by Dan Maas, copyrighted to Cornell and provided courtesy NASA/JPL-Caltech.

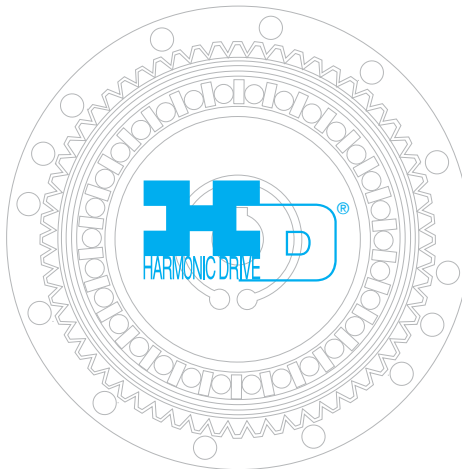

Glass and Ceramic Manufacturing Systems



Robots



Humanoid Robots

Source: Honda Motor Co., Ltd.



Printing, Bookbinding and Paper Machines

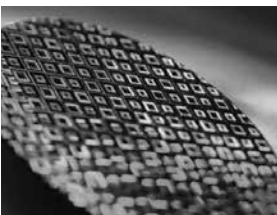

Semiconductor Manufacturing Equip.



Optical Equipment



Machine Tools



Paper-making Machines



Flat Panel Display Manufacturing Equip.

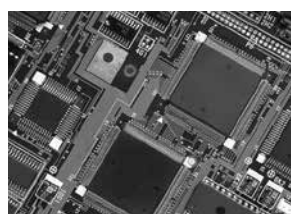

Printed Circuit Board Manufacturing Machines



Aerospace

Experts in Precision Motion Control

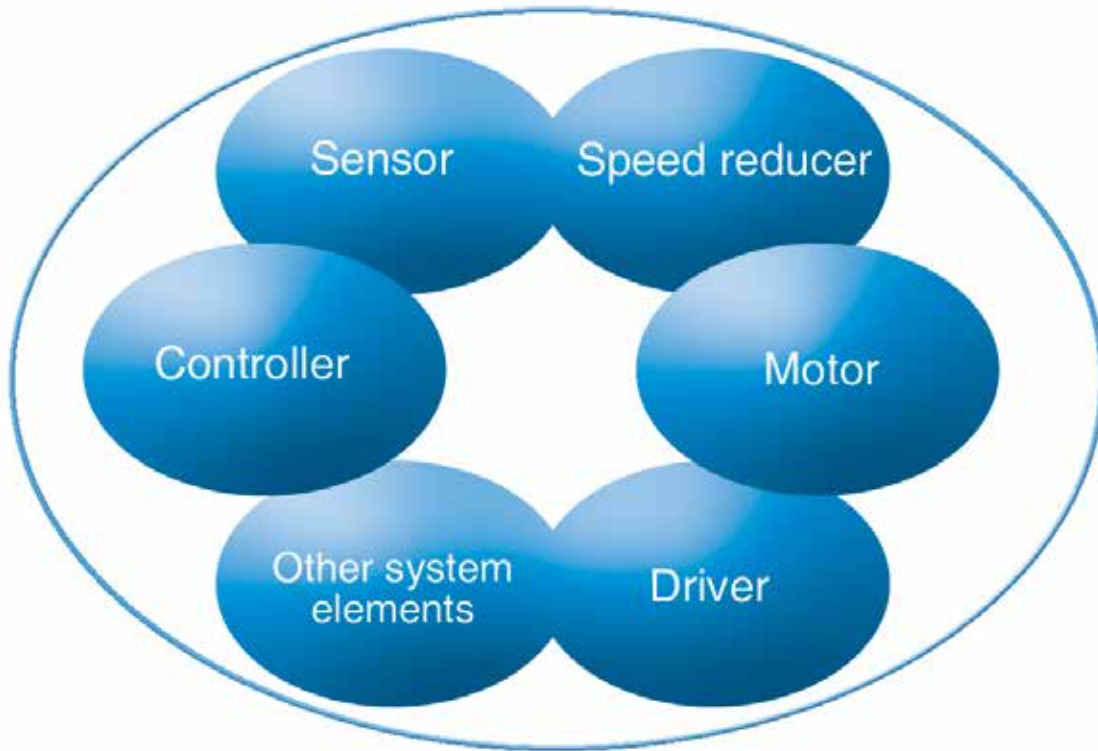

Other Products

HarmonicDrive® Gearing

HarmonicDrive® speed reducer delivers precise motion control by utilizing the strain wave gearing principle.

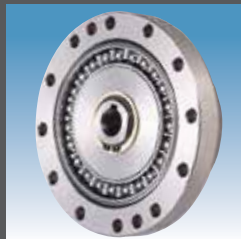

Rotary Actuators

High-torque actuators combine performance matched servomotors with HarmonicDrive® gears to deliver excellent dynamic control characteristics.

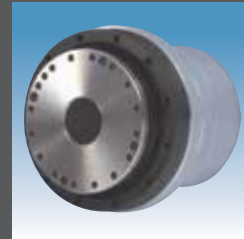

Linear Actuators

Compact linear actuators combine a precision lead screw and HarmonicDrive® gear. Our versatile actuators deliver both ultra precise positioning and high torque.



CSF Mini Gearheads

CSF mini gearheads provide high positioning accuracy in a super-compact package.



Harmonic Drive LLC

Boston US Headquarters

247 Lynnfield Street
Peabody, MA 01960

New York Sales Office

100 Motor Parkway
Suite 116
Hauppauge, NY 11788

California Sales Office

333 W. San Carlos Street
Suite 1070
San Jose, CA 95110

Chicago Sales Office

137 N. Oak Park Ave., Suite 410
Oak Park, IL 60301

T: 800.921.3332

T: 978.532.1800

F: 978.532.9406

www.HarmonicDrive.net

Group Companies

Harmonic Drive Systems, Inc.
6-25-3 Minami-Ohi, Shinagawa-ku
Tokyo 141-0013, Japan

Harmonic Drive AG
Hoenbergstrasse, 14, D-6555
Limburg/Lahn Germany

Harmonic Drive®, Harmonic Gearhead®, Harmonic Planetary® and Quick Connect® are registered trademarks of Harmonic Drive LLC. All other trademarks are property of their respective owners.

